

Type test procedure for 24 &48 Optical Fibre

Type Test procedures on optical fibre are listed in the below table:

No	Item	Acceptance Criteria	Test procedure	Test result (pass/fail)
1	Attenuation	Max.: ≤ 0.35 dB/km at 1310nm	IEC 60793-1-40	
		Max.: ≤ 0.21 dB/km at 1550nm	EIA/TIA 455-78A	
2	Attenuation Variation with Wavelength	0.05dB/km (1525nm to 1575nm) 0.05dB/km (1285nm to 1330nm)	IEC 60793-1-40 EIA/TIA 455-78A	
3	Attenuation at water peak	Max.: ≤ 0.35 dB/km at 1383nm	IEC 60793-1-40 EIA/TIA 455-78A	
4	Temperature Cycling (Temperature Dependence of Attenuation)	≤ 0.05 dB (-60° C to +85° C), 2 Cycles	IEC 60793-1-52 EIA/TIA 455-3A	
5	Attenuation with Bending (Bend Performance) a)75mm dia ± 2 mm., 100 turns @ 1310nm b)60mm dia ± 2 mm., 100 turns @ 1550nm c)32mm dia ± 2 mm., 1turn @ 1550	≤ 0.05 dB P	IEC 60793-1-47 EIA/TIA 455-62A	
		≤ 0.05 dB		
		≤ 0.5 dB		
6	Point Discontinuities of Attenuation	≤ 0.1 dB	IEC 60793-1-40 EIA/TIA 455-59	
7	Mode Field Diameter	9.2 ± 0.4 μ m at 1310nm	IEC 60793-1-45 EIA/TIA 455-164A/167A/174A	
8	Core-Clad Concentricity Error	≤ 0.5 μ m	IEC 60793-1-20 EIA/TIA 455-176	
9	Cladding Diameter	125 ± 1.0 μ m	IEC 60793-1-20 EIA/TIA 455-176	
10	Chromatic Dispersion	≤ 3.5 ps/ (nm·km) from 1280nm to 1339nm	IEC60793-1-42 EIA/TIA 455 168A/169A/175A	
		≤ 5.3 ps/ (nm·km) from 1271nm to 1360nm		
		≤ 18 ps/(nm·km) at 1550nm		
	Zero Dispersion wavelength	1312 nm ± 12 nm		
	Zero Dispersion slope:	≤ 0.092 ps/nm ² .km		
11	Fiber Tensile Proof Testing	≥ 0.69 Gpa	IEC 60793-1-31 EIA/TIA 455-31B	
-End of Table-				

TYPE TEST PROCEDURE FOR OPTICAL FIBER
Attenuation

Test Name : Attenuation.
 Final Customer : Power Grid Corporation of India Limited :
 Project Name :
 Optical fiber Manufacturer :
 Fibre Type :
 Standard : IEC 60793-1- 40, EIA/TIA 455-78A.

Test Set-up

An optical time-domain reflectometer (OTDR) is prepared and used for Transmission performance testing, which consists of the following minimum list of components and block diagram is show below.

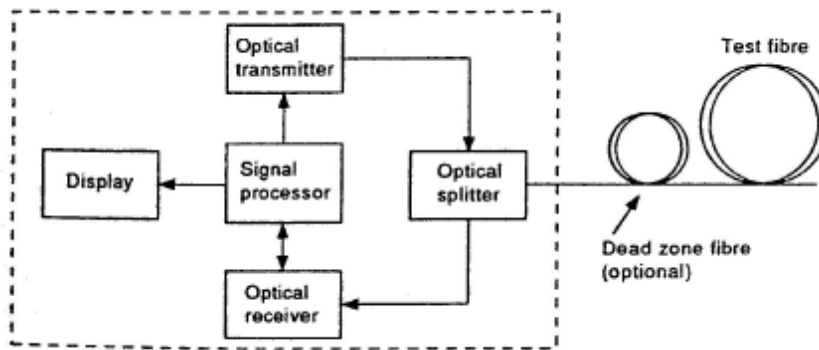
Test Procedure

Used an OTDR for indirect measurement of attenuation or fiber attenuation coefficient of the optical fiber by performing this measurement at multiple wave lengths; connected the specimen either to the instrument or to one end of the dead-zone fiber. Connected the other end of the dead-zone fiber to the instrument. The attenuation coefficient and accurate distance were recorded with the effective group-delay index of the specimen determined in advance.

Acceptance Criteria

- A) Any permanent increases in optical attenuation greater than 0.35 dB/km at nominally 1310nm shall constitute failure.
- B) Any permanent increases in optical attenuation greater than 0.21 dB/km at nominally 1550nm shall constitute failure.

Conclusion

The fiber meets the acceptance criteria of fiber attenuation test.

Tested by: (Sign with date)

Witnessed by: (Sign with date)

TYPE TEST PROCEDURE FOR OPTICAL FIBER

Attenuation Variation with wave length Test

Test Name : Attenuation Variation with wave length Test .
Final Customer : Power Grid Corporation of India Limited :
Project Name :
Optical fiber Manufacturer :
Fibre Type :
Standard : IEC 60793-1-40,EIA/TIA 455-78A.

Test Set-up

The cut-back technique is the only method directly derived from the definition of fibre attenuation, in which the power levels, P1 (λ) and P2 (λ) , are measured at two points of the fibre without change of input conditions. P2 (λ) is the power emerging from the end of the fibre, and P1 (λ) is the power emerging from a point nears the input after cutting the fibre.

Test Procedure

First cleared the optical fiber and cut the end of the optical fiber smoothly, then put the processed optical fiber to V notch. It must be ensured that processed optical fiber connect the end of preset pigtail.

Second choose the attenuation test key and checked the display on computer. The spectrum value should be recorded with different wavelength.

Acceptance Test

A) Any permanent increases in optical attenuation greater than 0.05 dB at nominally 1525nm to 1575nm shall constitute failure.

B) Any permanent increases in optical attenuation greater than 0.05 dB at nominally 1285nm to 1330nm shall constitute failure.

Conclusion

The fiber meets the acceptance criteria of fiber attenuation variation with wavelength test.

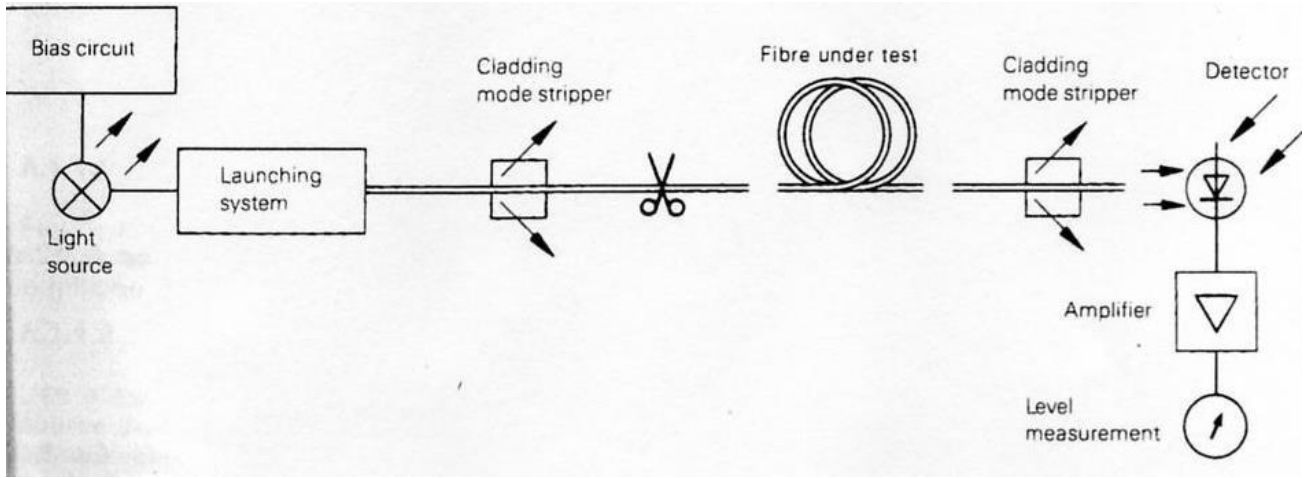

A.1- Arrangement of equipment to make loss measurement at one specified wavelength.

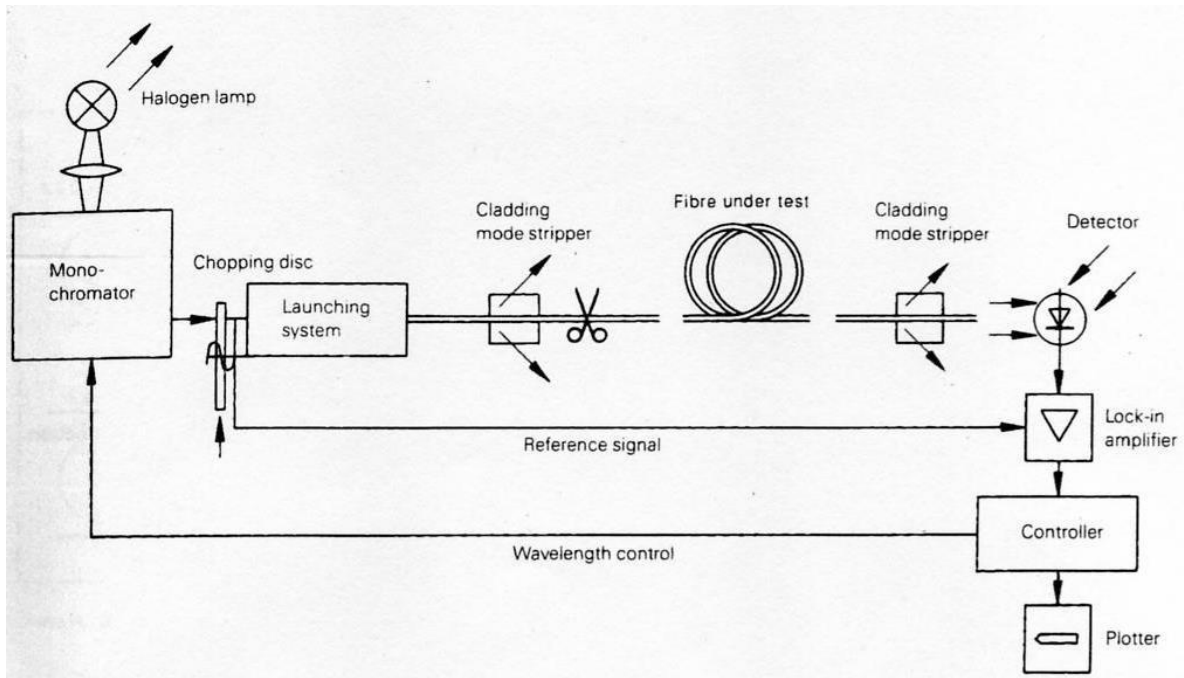

A.2- Arrangement of equipment used to obtain loss spectrum

Tested by:
(Sign with date)

Witnessed by:
(Sign with date)

TYPE TEST PROCEDURE FOR OPTICAL FIBER
Attenuation at Water Peak

Test Name : Attenuation at Water Peak.
Final Customer : Power Grid Corporation of India Limited
Project Name :
Optical fiber Manufacturer :
Fibre Type :
Standard : IEC 60793-1- 40, EIA/TIA 455-78A.

Test Set-up

Any optical fiber multi-parameter analysis is to be prepared and used for attenuation at water peaking testing

Test Procedure

- A) First cleared the optical fiber and cut the end of the optical fiber smoothly, then put the processed optical fiber to V notch. It must be ensured that processed optical fiber connect the end of preset pigtail.
B) Second choose the attenuation test key and checked the display on computer. The attenuation value recorded at 1383nm.

Acceptance criteria

- A) Any optical attenuation greater than 0.35dB/km at nominally 1383nm shall constitute failure.

Conclusion

The fiber meets the acceptance criteria of fiber attenuation at water peak test.

Tested by:
(Sign with date)

Witnessed by:
(Sign with date)

TYPE TEST PROCEDURE FOR OPTICAL FIBRE
Temperature Cycling

Test Name : Temperature cycling .
 Final Customer :Power Grid Corporation of India Limited
 Project Name :
 Optical fiber Manufacturer :
 : 24B1-55(58.7:40.3), 48B1-55 (58.7:40.3)
 Fibre Type
 Standard : IEC 60793-1-52,EIA/TIA 455-3A.

Test Set-up

An optical time-domain reflectometer (OTDR) is prepared and used for Transmission performance testing, which consists of the following minimum list of components and block diagram is show below.

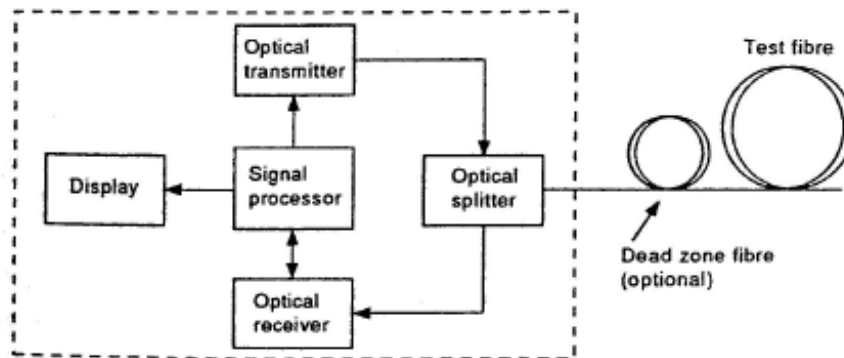

Figure.1 - Block diagram of an OTDR

Test Procedure

Use an OTDR for indirect measurement of attenuation or fiber attenuation coefficient of the optical fiber by performing these measurements at multiple wave lengths; connect the specimen either to the instrument or to one end of the dead-zone fiber. Connect the other end of the dead-zone fiber to the instrument. The attenuation coefficient and accurate distances are recorded with the effective group-delay index of the specimen determined in advance.

For Temperature Cycling (Temperature Dependence of Attenuation) test, the specimen under test i.e. optical fiber of length $\geq 2,000$ meters is placed in a chamber and subjected to changes in temperature for duration & specifications as below and the attenuation is measured using OTDR.

Minimum temperature : -60°C
 Maximum temperature : +85°C
 Minimum dwell time at each temperature : 2hr.
 Maximum rate of change of temperature : 1°C/min
 Number of consecutive cycle : 2

The length of fibre outside the chamber shall not be more than 10% of the total sample lengths.

Acceptance criteria

- A) Any optical attenuation greater than 0.05dB at nominally 1310nm shall constitute failure.
- B) Any optical attenuation greater than 0.05dB at nominally 1550nm shall constitute failure. .

Conclusion

The fiber meets the acceptance criteria of fiber temperature cycling test.

Tested by: (Sign with date)

Witnessed by: (Sign with date)

TYPE TEST PROCEDURE FOR OPTICAL FIBER
Attenuation with Bending (Bend Performance)

Test Name : Attenuation with Bending (Bend Performance).
Final Customer :Power Grid Corporation of India Limited Project
Name :
Optical fiber Manufacturer :
Fibre Type : Standard : IEC 60793-1-47, EIA/TIA 455-62A.

Test Setup

Mandrel each with a diameter of 75mm, 60mm & 32mm for single-mode fibers and a loss measurement instrument is prepared. Determine the macro bending loss at 1550nm & 1310nm with optical power meter.

Test Procedure

Loosely wind the fiber on the mandrel, avoiding excessive fiber twist for 100 turns with mandrel diameter 60mm & 75mm and 1 turn with mandrel diameter 32mm to test at wavelength 1550nm & 1310nm for the fiber. In order to determine the induced attenuation due to macro bending, the value is corrected for the intrinsic attenuation of the fiber. The fiber length outside the mandrel and the reference cut-back length are free of bend. The optical power meter are monitored for test.

Acceptance criteria

- A) Any permanent increase optical attenuation greater than 0.05dB at nominally 1310nm for 75mm ± 2mm dia. 100 turns shall constitute failure.
- B) Any permanent increase optical attenuation greater than 0.05dB at nominally 1550nm for 60mm ± 2mm dia. 100 turns shall constitute failure.
- C) Any permanent increase optical attenuation greater than 0.5dB at nominally 1550nm for 32mm ± 0.5mm dia.1 turn shall constitute failure.

Conclusion

The fiber meets the acceptance criteria of fiber attenuation with bending test.

Tested by: (Sign with date)

Witnessed by: (Sign with date)

**TYPE TEST PROCEDURE FOR OPTICAL FIBER
Point Discontinuities of Attenuation**

Test Name : Point Discontinuities of Attenuation.
 Final Customer :Power Grid Corporation of India Limited, India.
 Project Name :
 Optical fiber Manufacturer :
 : Fibre Type
 Standard : IEC 60793-1-40, EIA/TIA 455-59.

Test Set-up

An optical time-domain reflectometer (OTDR) is prepared and used for Transmission performance testing, which consists of the following minimum list of components and block diagram is show below.

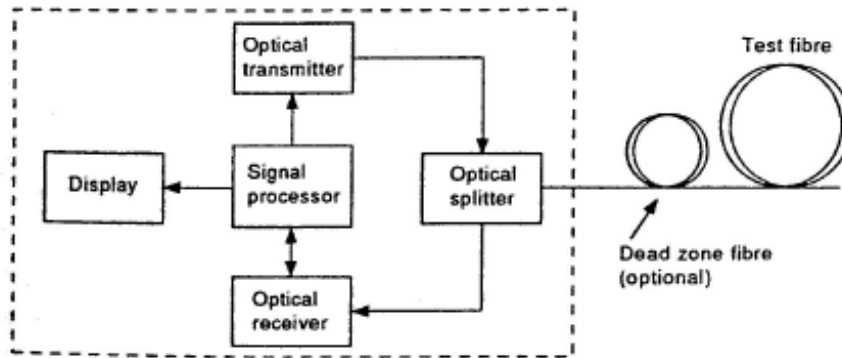

Test Procedure

1. Connect the test sample either to the instrument or to one end of end dead-zone fiber (if used). Connect the other end of the dead-zone fiber (if used) to the instrument.
2. If the accurate locations of point defects are to be recorded, the effective group delay index of the test sample is required. If this value is not known, use **FOTP-60** to determine it.
3. Enter OTDR parameters such as source wavelength, pulse duration, length range, and signal averaging into the instrument, along with the test sample effective group index. The values of some of these parameters may be present in the instrument.
4. Adjust the instrument to display a backscatter signal from the test sample. It may be advantageous to begin with coarse vertical and horizontal scaling to maximize the length displayed. An example is given in Figure 1. 5. Examine the OTDR signal along the test sample for point defects. If increased resolution is need, adjust the graphical display, if possible, to expand the section of interest to large scale (exercising care to assure that proper reading of the true signal can still be distinguished from the noise points); an example is given in Figure.2.
6. To determine that a point defect (rather than an attenuation non-uniformity situation) exist observe the area in question using two different pulse durations. The shape of the loss or gain changes with the pulse duration, the anomaly is a point defect. If the shape does not change, the anomaly shall be considered to be attenuation non-uniformity to be measured by **FOTP-61**.

7. Report any point defect deviations which exceed the value specified in the detail specification. Describe the nature of these faults (e.g. apparent loss or gain, reflection, duration, etc) as required by the Detail Specification.

7.1. Determine the defect location, if required, by placing a cursor at the beginning (or at another point specified by the OTDR manufacturer) of a power rise or drop, this may be difficult to do at a drop. Obtain the distance coordinate via the alphanumeric display.

7.2. Obtain the apparent loss or gain of the defect, if required, by the method described by the OTDR manufacturer. Some instruments required placement of a pair of cursors on each side of the defect. The two best-fit straight lines (from a two-point or least-squares fit for each) are extrapolated to the defect location. If available, the linear fit method should be chosen. The vertical separations of the lines give the apparent loss or gain. Note any reflection peak.

7.3. When possible, repeat the test for single launched into the test sample in the opposite direction. A more accurate loss estimate (and the elimination of apparent gain) is made by averaging readings taken directionally at the same wavelength. This eliminates the effect of any backscatter different for the fiber sections on both side of the defect.

7.4. If required by the Detail specification, repeat the test at another wavelength.

Acceptance Criteria

A) Any permanent increases in optical attenuation greater than 0.1 dB/km at nominally 1310nm shall constitute failure.

B) Any permanent increases in optical attenuation greater than 0.1 dB/km at nominally 1550nm shall constitute failure.

Conclusion

The fiber met the acceptance criteria of fiber point discontinuities of attenuation test.

Tested by: (Sign with date)

Witnessed by: (Sign with date)

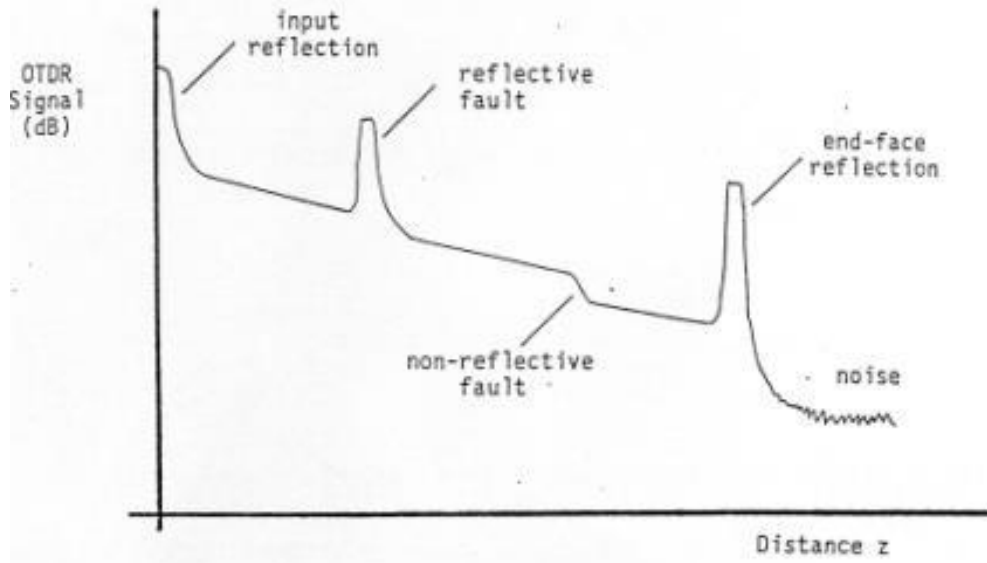

Figure 1. Schematic of an OTDR Trace. Point defects with apparent loss are shown, one reflective and one non-reflective.

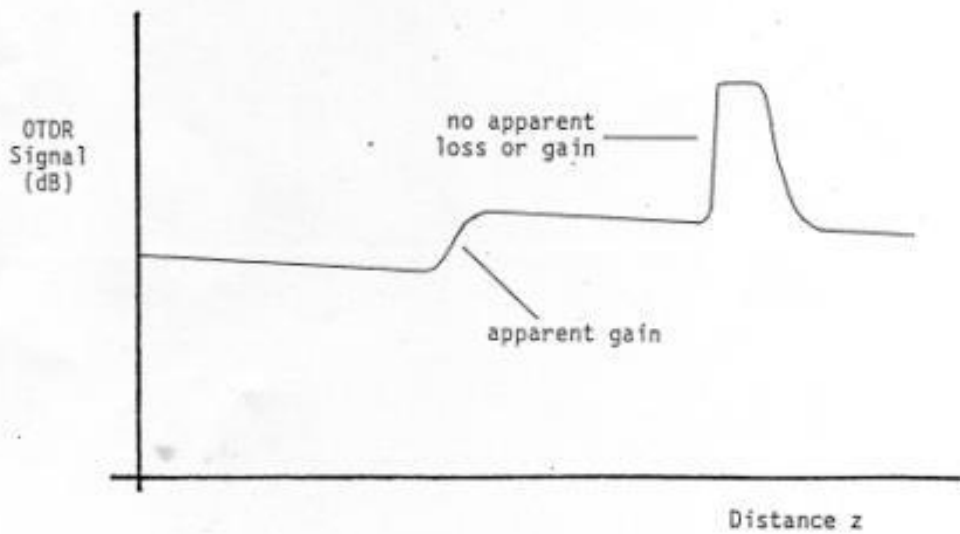

Figure 2. Schematic of an expanded OTDR trace. Two point defects are shown, one with apparent gain, and another with no apparent loss or gain.

TYPE TEST PROCEDURE FOR OPTICAL FIBER
Core-Clad Concentricity Error

Test Name : Core-clad Concentricity Error.
Final Customer : Power Grid Corporation of India Limited, India.
Project Name :
Optical fiber Manufacturer :
Standard : Fibre Type
:IEC 60793-1- 20, EIA/TIA 455-176.

Test Set-up

Suitable incoherent light sources was used for the illumination of the core and the cladding. Adjustable in intensity and stable n intensity over a time period sufficient to perform the measurement.

For the grey-scale method a CCD video camera was used to detect the magnified output near-field Image and transmit it to a video monitor. The video digitizer performance the digitization of the image for further computer analysis. This video system was sufficiently linear such that,after calibration, the measurement uncertainty was not great than required.

For single near-field scan method a means was provided to scan the focused image of the fiber near-field pattern which provides knowledge of the distance scanned. An example was a single detector (such as a PIN-hole) placed on a stepper-motor driven translator with position feedback device, or a video array detector of know element size and spacing. The detector was linear over the range of intensities encountered.

Test Procedure

First cleared optical fiber and cut the end of optical fiber smoothly, then put the processed optical fiber to V notch. It must be ensured that processed optical fiber connect the end of preset pigtail.

Second choose the attenuation test key and checked the display on computer. The mode field diameter was recorded.

Acceptance Criteria

The core-clad concentricity error greater than $0.5\mu\text{m}$ shall constitute failure.

Conclusion

The fiber meet the acceptance criteria of fiber core-clad connectivity error test.

Tested by: (Sign with date)

Witnessed by: (Sign with date)

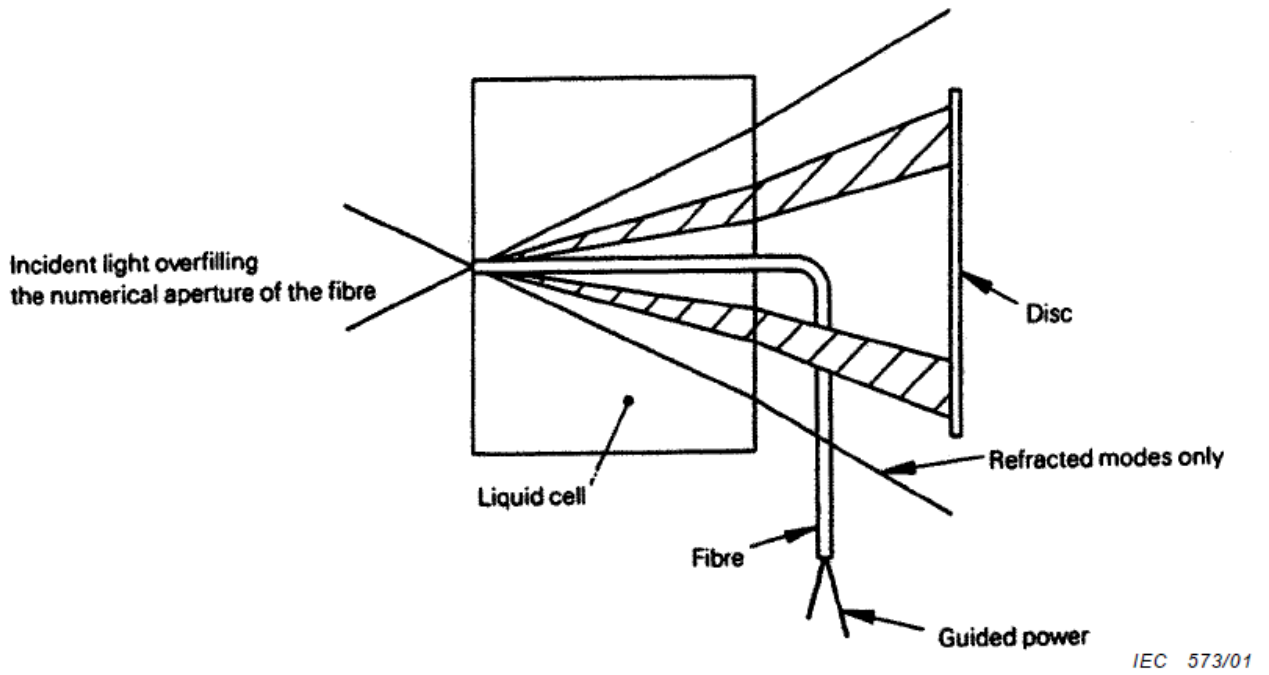
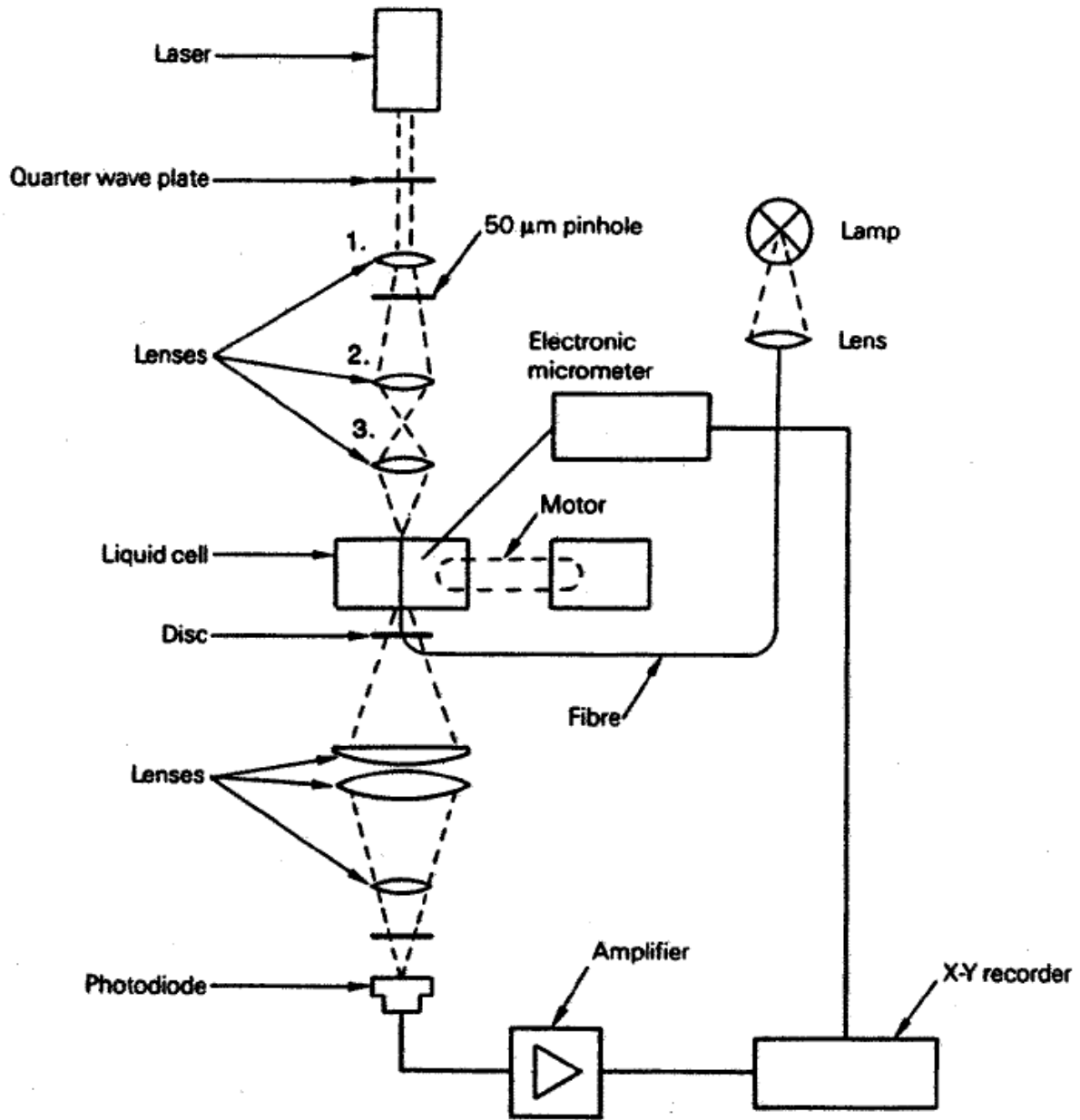

Figure2: Refracted near-field method-Schematic diagram



IEC 574/01

Figure3: Typical arrangement of the refracted near-field test set

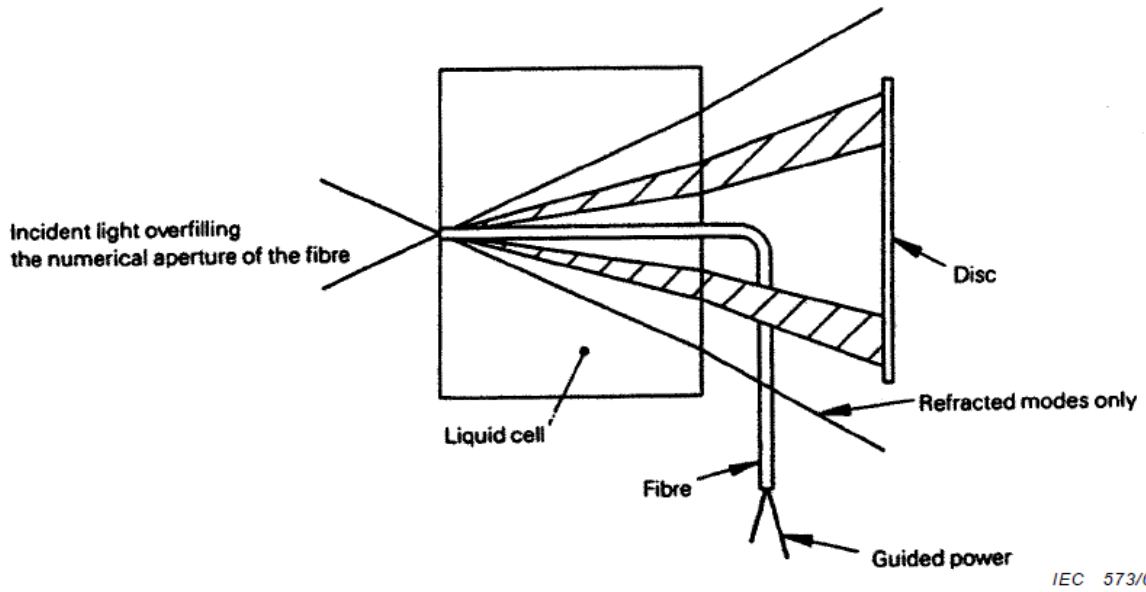

Figure2: Refracted near-field method-Schematic diagram

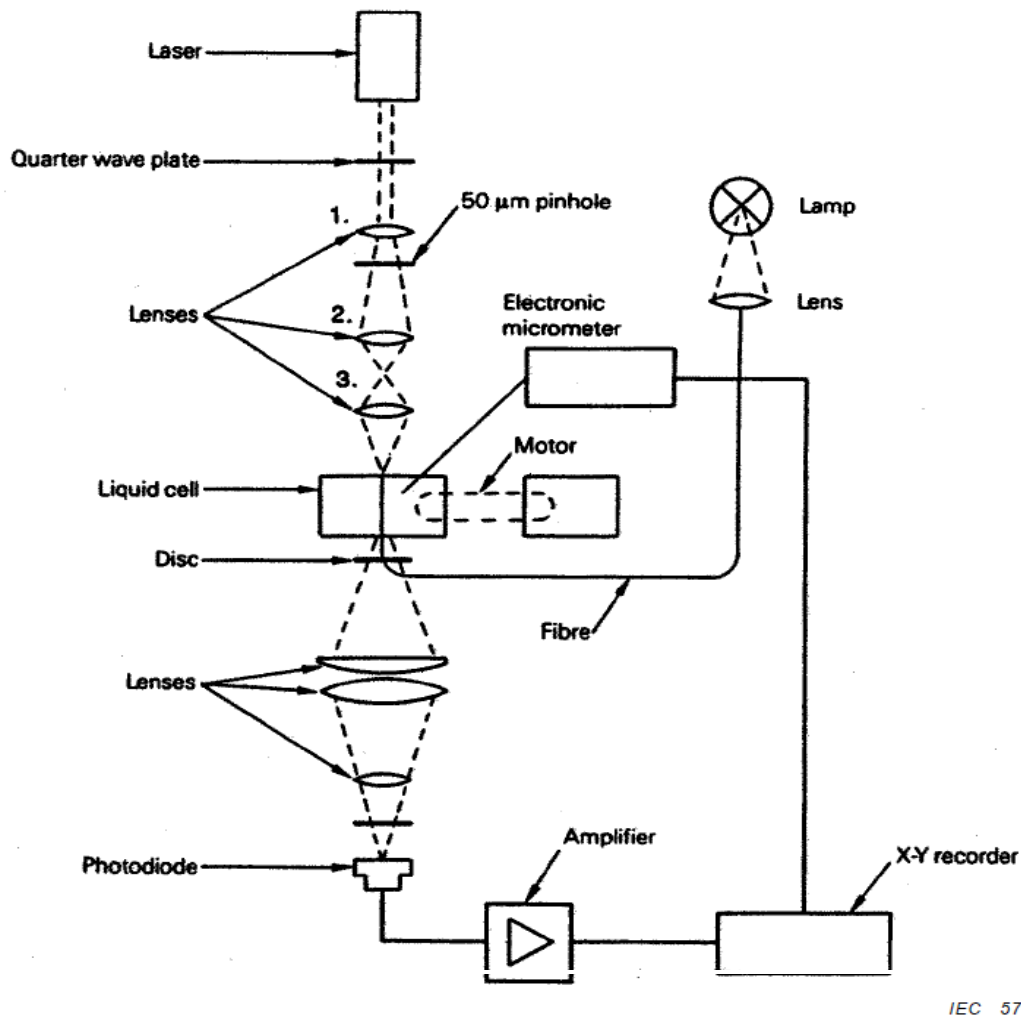

Figure3: Typical arrangement of the refracted near-field test set

**TYPE TEST PROCEDURE FOR OPTICAL FIBER
Chromatic Dispersion Test**

Test Name : Chromatic Dispersion Test.
Final Customer : Power Grid Corporation of India Limited, India.
Project Name :
Optical fiber Manufacturer :
: Fibre Type
Standard : IEC 60793-1-42, EIA/TIA 455 168A/169A/175A.

Test Set-up (Chromatic Dispersion)

The test sample shall be on fiber or cable as specified in the detail specification, of know length greater than 1 km long to produce adequate phase measurement accuracy. For a 3-wavelength system, the minimum length can be estimated from equation.

A phase calibration fiber of the same fiber class as the test sample shall be used to facilitate input phase measurement or input phase equalization. The length of this fiber shall be less than or equal to 0.2% of the test fiber length.

Test Procedure

The phase calibration fiber shall be connected to the measurement apparatus; a reference signal shall also be established. The phase, for each signal source shall be measured and recorded.

Alternately to above, if the signal sources are phase adjustable, then with the phase calibration fiber in place, the phases of all signal sources shall be equalized. Test sample measurements shall then be performed as describe in below.

The test fiber shall be connected to the measurement apparatus; a reference signal shall be also be established.

Acceptance Criteria:

- a)The Chromatic dispersion greater than 3.5 ps/(nm.km) at nominally 1280nm to 1339nm shall constitute failure.
- b)The Chromatic dispersion greater than 5.3 ps/(nm.km) at nominally 1271nm to 1360nm shall constitute failure.
- c)The Chromatic dispersion greater than 18 ps/(nm.km) at nominally 1550nm shall constitute failure.
- d)The Zero dispersion wavelength less than 1300nm or greater than 1324nm shall constitute failure
- e)The Zero dispersion slope greater than 0.092 ps/nm².km shall constitute failure.

Conclusion:

The fiber meets the acceptance criteria of fiber attenuation with bending test .

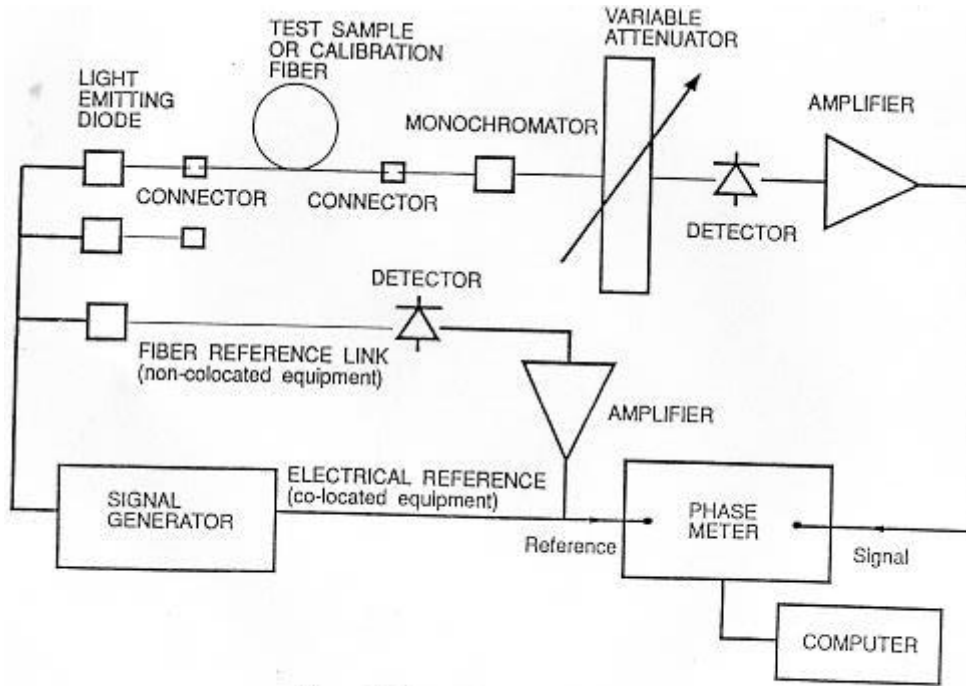

Figure 2: Chromatic Dispersion Test Set LED System

Figure : Chromatic Dispersion Test set-LED System

Tested by:(Signed with date)

Witnessed by:(signed with date)

TYPE TEST PROCEDURE FOR OPTICAL FIBER

Fiber Tensile Proof Test

Test Name : Fiber Tensile Proof Test.
Final Customer : Power Grid Corporation of India Limited, India.
Project Name :
Optical fiber Manufacturer :
Standard : Fibre Type
: IEC 60793-1-31, EIA/TIA 455-31B.

Test Set-up (Fiber Tensile Proof)

To measure fiber proof with the indicated general operating requirements, the braked capstan type machine is used. Care should be used in the design so as to prevent coating damage.

Test Procedure

The test specimen is fed into the machine according to the operating instructions for the machine. Set the tension load on the machine according to the provision in the sub procedure given in the following form. The procedure allows easy detection by the operator of any failure in the fiber, if or when it occurs. The test specimen is run through the proof test machine with 1sec.

The tension value shall be recorded by Newton.

Acceptance Criteria:

- a)Fibre breakage during the test shall constitute failure
- b)The stress σ on the test fiber was 0.69 GPa
- c)The strain ϵ on fibre was greater than 1.0%

Conclusion:

The fiber met the acceptance criteria of fibre tensile proof test.

Tested by:
(Sign with date)

Witnessed by:
(Sign with date)

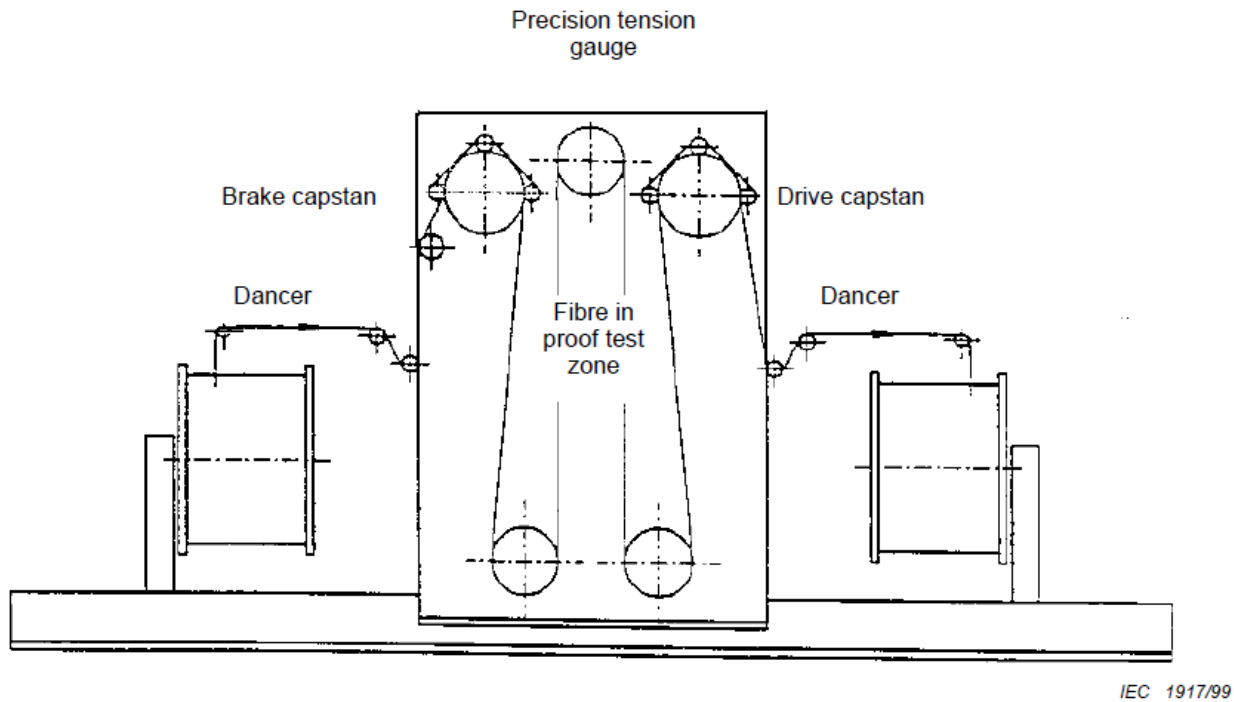

Fibre pay-off region
Stage 1 : constant pay-off

Proof testing region
Stage 2 : Proof testing with master braking capstan and precision tension gauge

Fibre take-up region
Stage 3 : Constant tension take-up spooling

Figure 5 - Braked capstan machine